

14 - Dimensions, designs, mounting positions of bevel helical gearmotors

Mounting positions

Unless otherwise stated, gear reducers are supplied in mounting position **B3** (see ch. 2).

MR C3I 50 ... 125

Designs:

- U03A
- U03Asin
- U03D
- U03Dsin

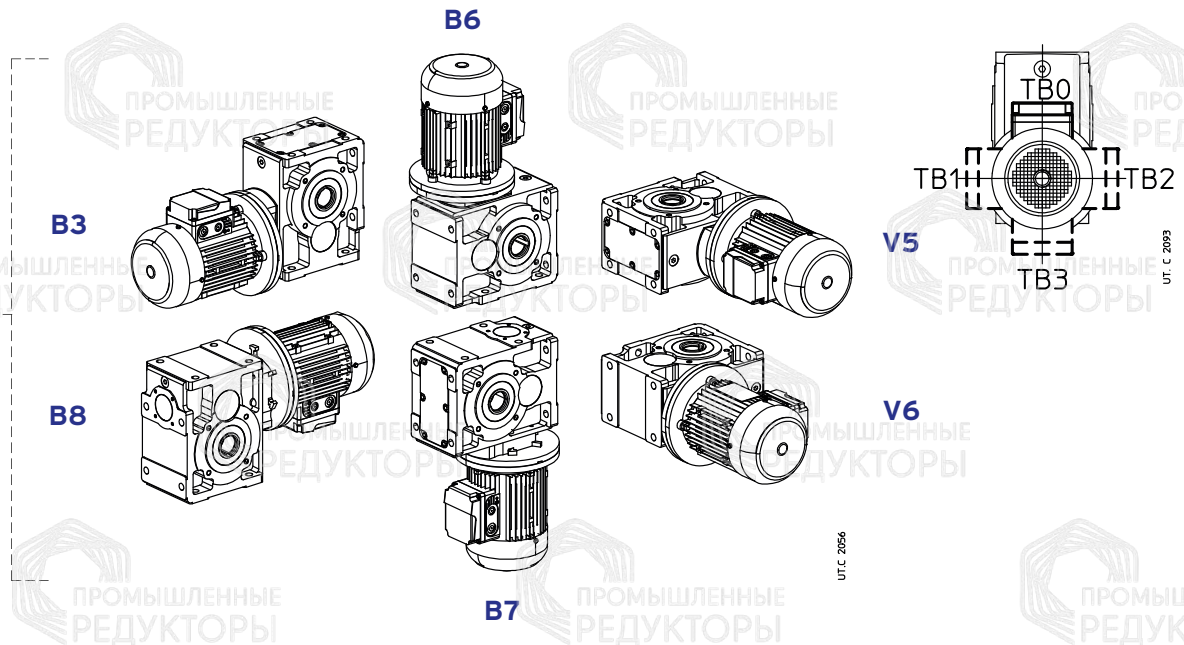

Oil quantity MR C3I 50 ... 125

Lubricant quantities [l] stated are approximate for provisioning. The exact oil quantity the gear reducer is to be filled with is defined by the level plug.

| Mounting position | 50 | 63, 64 | 80, 81 | 100 | 125 |
|-------------------|------|--------|--------|-----|------|
| B3 | 0,5 | 1,2 | 1,9 | 3,3 | 6,4 |
| B8 | 0,7 | 1,4 | 2,5 | 4,5 | 9,5 |
| B7 | 0,5 | 1,2 | 1,9 | 3,3 | 6,4 |
| B6 | 0,9 | 1,8 | 3 | 6,3 | 12,8 |
| V5 | 0,55 | 1,35 | 2,3 | 4,1 | 7,5 |
| V6 | 0,55 | 1,35 | 2,3 | 4,1 | 7,5 |

14 - Dimensions, designs, mounting positions of bevel helical gearmotors

Lubrication details

MR C3I 100 ... 125

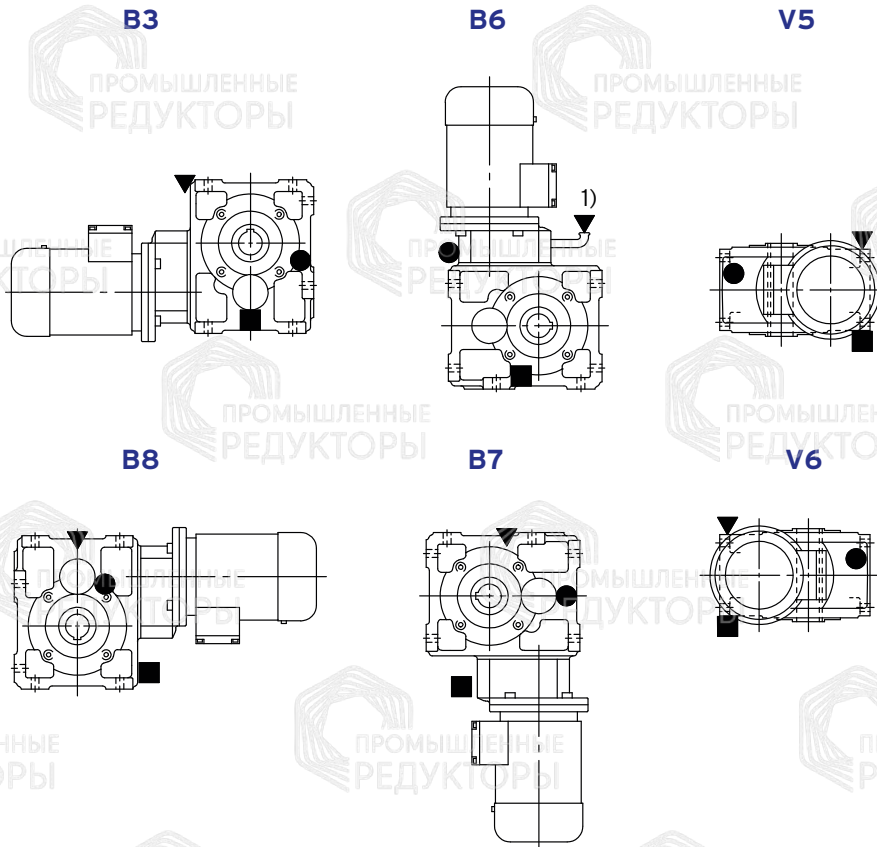

Designs:
 U03A
 U03Asin
 U03D
 U03Dsin

UT.C. 100/1A

1) See also ch. 6 page 43.

- ▼ oil filler plug
- oil level plug
- oil drain plug
- ▼ oil filler plug on opposite side (not in view)
- oil level plug on opposite side (not in view)
- oil drain plug on opposite side (not in view)